

Micom Americas, Inc.
SW800 AUTOMATIC SWING DOOR OPERATOR

Operations & Installation Manual

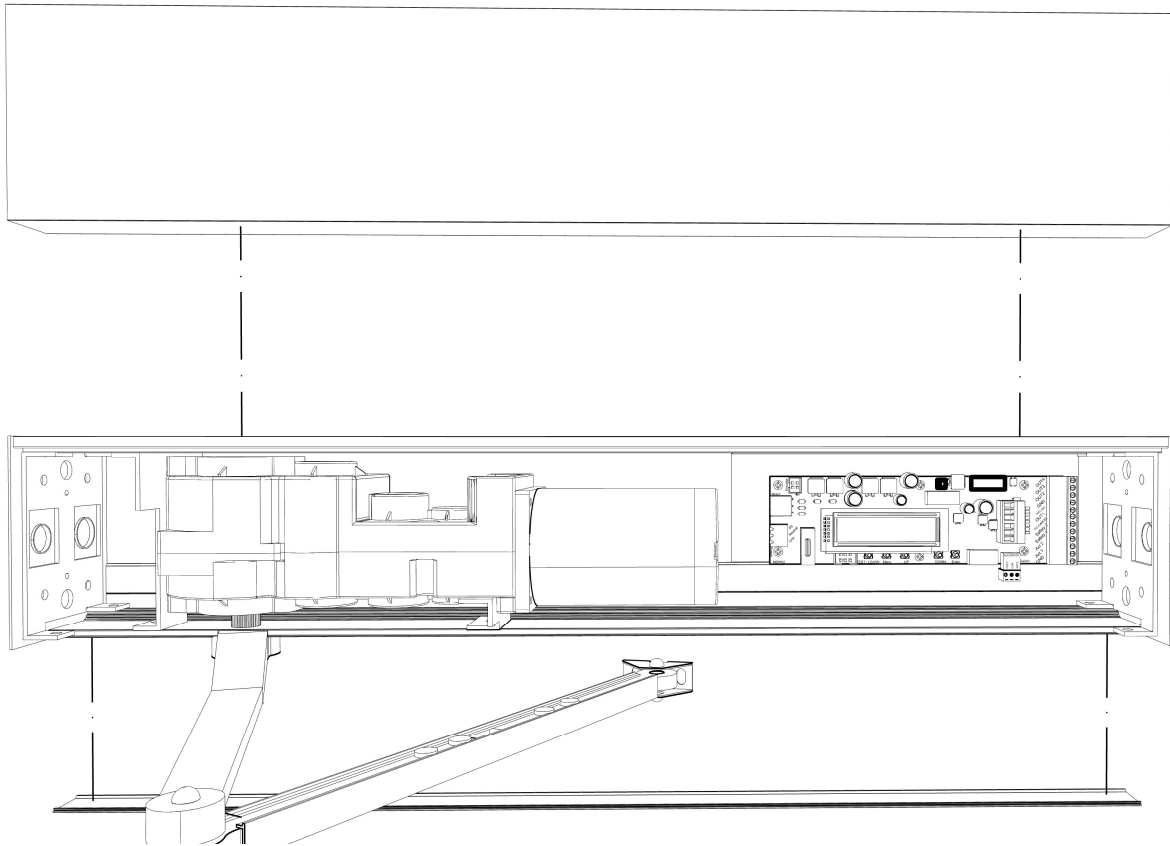

*These installation instructions detailed within are solely for professional installers
and are not intended to be handed over to the end user.*

Ver. April 3, 2023



Micom Americas, Inc.
220 Viceroy Road, Unit 15
Concord, ON L4K 3C2, Canada

Tel: (905) 851-8688

Web: www.micomamericas.ca
Email: <mailto:sales@micomamericas.ca>



WARNING



Failure to observe the information in this manual may result in personal injury or damage to the equipment. To reduce the risk of injury to persons, use this operator with single or double pedestrian swinging doors only.

SAVE THESE INSTRUCTIONS FOR FUTURE REFERENCE

AVOIDANCE OF ELECTRIC SHOCK, INJURY, FIRE OR MALFUNCTIONS

	Please read these instructions carefully before installing the door operator. We are not responsible for any loss or damage if these precautions are not followed. These instructions should be followed to avoid the possibility of injury and damage due to wrong installation or adjustment.
	During maintenance and installation, the power to the control unit should be OFF.
	Please use the correct power supply - Power Acceptance 90V-250V DC-50/60 Hz.
	Make sure that the operator is grounded or connected to earth! The coating of the operator is made of an electrically conductive metallic material which will easily induce electrical conduction. Make sure the ground or earth wire is connected.
	The operator housing is not completely sealed, therefore it should be noted that excessive moisture or a corrosive atmosphere could destroy the electronic components contained within.
	Do not remove screws and bolts from the structure of the Control Unit or Motor Gear Box. Do not intend to open, repair, or alter any part of the operator unit. Failure to comply will result in loss of warranty.
	Installation and maintenance of this product can be performed by trained and authorized personnel only.
	Before switching ON the power supply, make sure that no objects obstruct the travel of the automatic doors.
	NATIONAL WIRING REGULATIONS AND STANDARDS MUST BE CONFORMED TO.
	Follow all indicated instructions as improper installation could cause severe damage.
	Correct equipment must be used in order to reach overhead area for installation and service.
	KEEP FINGERS AND CLOTHING CLEAR OF ALL MOVING PARTS.
	Please keep these instructions
WARRANTY	36 MONTHS FROM SHIPMENT. WARRANTY VOID IF REPAIR IS ATTEMPTED TO MOTOR GEAR OR CONTROL ASSEMBLY.

TABLE OF CONTENTS

SECTION 1.0 - PRODUCT SUMMARY -----	4
SECTION 2.0 - TECHNICAL SPECIFICATION -----	5
SECTION 3.0 - RECEIVING INSPECTION -----	6
SECTION 4.0 - PRE-INSTALLATION INFORMATION -----	7
SECTION 5.0 - OPERATOR INSTALLATION -----	9
SECTION 6.0 - PUSH AND PULL ARMS INSTALLATION -----	14
SECTION 7.0 - LEARNING CYCLE AND START UP -----	17
SECTION 8.0 - ELECTRONICS CONTROLLER PROGRAMMING -----	18
BASIC SETTINGS TABLE DESCRIBING THE CONTROLS FUNCTIONS, SETTINGS, VALUES AND DEFAULTS-----	23
SECTION 9.0 - WIRING CONNECTIONS -----	25
SECTION 10.0 - CHANGING HANDING OF OPERATOR -----	29
SECTION 11.0 - SAFETY SIGNAGE AND DECALS -----	33
SECTION 12.0 - TROUBLESHOOTING-----	34
SECTION 13.0 - DAILY SAFETY CHECKLIST -----	36
SECTION 14.0 - ADDITIONAL INFORMATION -----	37
SECTION 15.0 - PRELOAD SPRING TENSION -----	38
SECTION 16.0 - DROP SPINDLE INSTRUCTIONS -----	39
SECTION 17.0 - MISCELLANEOUS/FUTURE USE-----	40
SECTION 18.0 - WARRANTY POLICY -----	41

Section 1.0 - Product Summary

SW800 is a universal, non-handed, electro-mechanical swing door operator which provides powered door opening upon activation. The unit is designed to facilitate barrier free access into and within building through swing doors.

When properly installed and programmed, this product complies with ANSI/BHMA A156.19 Standard for Power Assist and Low Energy Power Operated Swinging Doors.

SW800 features enable the continuous automation of pedestrian doors while offering Low energy barrier-free access. **(THE SW800 IS)** Designed to achieve the highest degree of safety while offering a long service life.

It is the responsibility of the installer and installation company to certify that the final completed operator is installed in accordance with local building codes, applicable laws, and ANSI 156.19 standards governing this product.

Opening

When an open signal is received by the control unit, the door is opened at the factory set or pre-adjust opening speed. Before the door is fully open, it will begin its back check, slowing automatically to low speed. The motor stops when the selected full open angle has been reached. The open position is held by the motor.

In case the door encounters an obstruction during the opening cycle, once the maximum current limit is reached for at least two (2) seconds, the door opening is then cancelled.

Closing

When the activation time has elapsed, the operator will close the door automatically using spring force and motor power. The door will slow to latch speed before it reaches the full closed position. The door is kept closed by spring power.

Power Failure

During power failure, the operator acts as a manual door closer with controlled closing speed.

SW800 can be surface mounted or overhead concealed mounted on either side of the door header for left, right, pull, or push applications. It is suitable for either single or double door opening being either hinged or center hung mounted.

ALL PRODUCT, PRODUCT SPECIFICATIONS AND DATA ARE SUBJECT TO CHANGE WITHOUT NOTICE TO IMPROVE RELIABILITY, FUNCTION OR DESIGN OR OTHERWISE.

It is the customer's responsibility to validate that a particular product with the properties described in the product specification is suitable for use in a particular application.

Section 2.0 - Technical Specification

1.0	Model	SW800
2.0	Application	Low Energy Swing Door Operator
3.0	Power Supply	100V - 240V AC, 50/60 Hz
4.0	Consumption	100W Max
5.0	Motor	1/4 Hp, Low revolution 24 DC, 3A Max
6.0	Rated Operation	Continuous opening and closing cycles
7.0	Reduction Gear	Enclosed Reduction Gear system
8.0	Control System	Microprocessor Digital Control
9.0	Operating Environment	Ambient temperature: -18° ~ +50° (no condensation or icing) Ambient humidity 30% to 85% RH (no hazardous materials must be present in the atmosphere)
10.0	Operation During Power Failure	Low manual resistance when opened by hand. Door closing by spring.
11.0	Operator Net Weight	17 kg, approx. 38 lbs.
12.0	Operator Dimensions	5½" (h) (140 mm) x 4½" (D) (115 mm)
13.0	Door Weight (max)	700 lbs. (318 kg) per leaf
14.0	Door Width Limits	30" up to 60" (consult factory for special sizes)
15.0	Operator Width	30" to 102"
16.0	Installation Types	Push, Pull, Overhead Concealed, Center spindle
17.0	Adjustable Opening Angle	80° to 180°
18.0	Auxiliary Power	500mA @ 24 vdc for accessories AND 1,000mA @ 12 vdc for accessories
19.0	Closing Force	Adjustable pressure by spring tension and optional motor close
20.0	Product Standards	UL 325 Listed by ETL #5012330 ANSI 156.19 Compliant UL10C Fire Door Rated Operator - 2 hours



CAUTION



Not compatible with 315 or 433MHz wireless devices.

Must use 900 MHz and higher frequency to ensure proper functioning.

Section 3.0 - Receiving Inspection

On receiving the package, please verify that the order was shipped complete and correct, including model number, header width, door handing, arm and color.

- If any of the below items are not correct, do not attempt to install the unit until all conditions are correct.
- Report any incorrect items immediately.

NO CLAIMS FOR SHORTAGE WILL BE ACCEPTED UNLESS REPORTED WITHIN 24 HOURS OF RECEIPT OF SHIPMENT. THE FOLLOWING ITEMS SHOULD BE SUPPLIED:

3.1 Exploded View

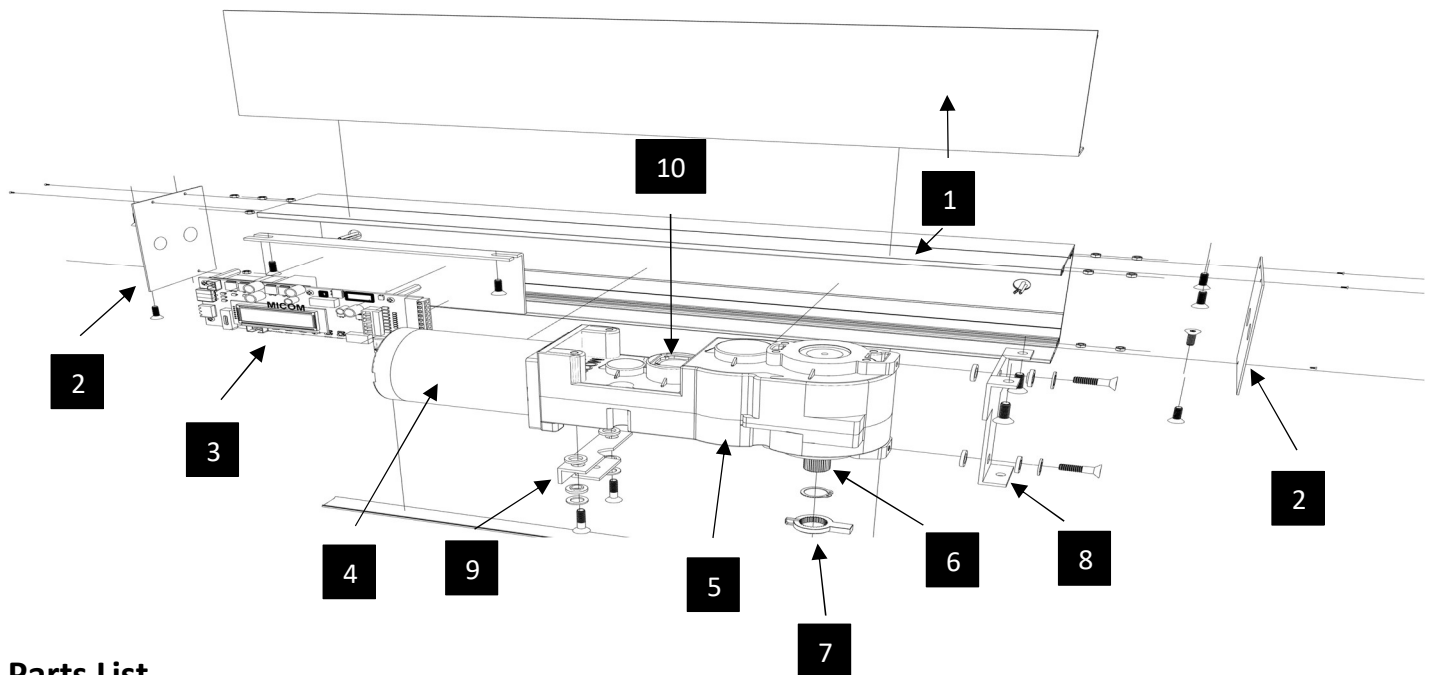

3.2 Parts List

No.	Description	Parts No.
1	SW800 Header/Housing	HDR
2	End cover plate	ECPL-800
3	Control Unit SW800	SW-CU-800
4	Motor	n/a
5	Gear Box/Motor Assembly	SW-MGB-800
6	Spindle	S-800
7	Mechanical door stop	MDS-800
8	Motor gear box end support bracket	MEB-800
9	Motor gear box mount bracket	MGBMB-800
10	Rev Counter/Encoder	SW-REV

Section 4.0 - Pre-Installation Information

4.1 Safety Precautions

- Only trained technicians are authorized to carry out these operations.
- Ensure all power is OFF to the unit before performing any work or maintenance.
- Do not climb or put weight on any door or header parts.
- Do not let children play with the operator or the electrical board.
- Keep remote controls away from children.

To avoid bodily injury, material damage, and malfunction of the product, the instructions contained in this manual must be strictly observed during installation, adjustment, repair, and service.

Training is needed to carry out these tasks safely.

4.2 Compliance Codes and Standards

It is the responsibility of the final installer and/or installation company to certify that the final completed operator is installed in accordance with ANSI/BHMA A156.19 Standard for Power Assist and Low Energy Power Operated Swing Doors, local building codes and applicable laws.

Be sure to complete the site inspection and acceptance test before taking the door into operation.



CAUTION



- All wiring must conform to standard wiring practice in accordance with national and local wiring codes.
- Door must swing freely through the entire opening and closing cycle before beginning of installation.
- Incorrectly installed or improperly adjusted door operators can cause property damage or personal injury.
- All dimensions are given in inches (millimeters), unless otherwise noted.
- Before installation, verify door frame is properly reinforced and is well anchored in the wall.
- Concealed electrical conduit and concealed switch or sensor wires should be pulled to the frame before proceeding.

4.3 Electrical

The 115+/-5 VAC supply lines are connected into the Green Connector block located to the left hand side of the control unit. Words clearly indicate its correct wiring. The ground wire is also connected into the Green Connector block.

The control board settings have been pre-set prior to shipment. It will be necessary for the door operator to be functional while adjustments and settings are made. Please follow these instructions for a successful installation.

A black push actuator button indicated by "TEST/LEARN" is mounted to the lower left corner of the visual display to ease in the adjustment process.

Once the unit is powered up and before the arm is installed, push the "TEST/LEARN" button in order to check the spline drive shaft rotates in the correct direction.

Keep all wires away from moving parts and sharp edges that may cut into the outer casing of the wires.

Installation of any extra wiring for controls or accessories into the header unit shall be secured and away from any moving parts.

If the motor is not plugged into the circuit board, there is no resistance against the spring when manually opening the door. **The door or arm will close very quickly if opened.**

If an electrical access hole is added or knocked out of the end plates, code approved electrical transfers must be used. Hole cannot be knocked out and unfilled.

4.4 Required Tools for Installation

- Allen Wrench Set
- Power Drill and Drill Bits
- Level
- Tape Measure
- Wire Stripper
- Screwdrivers: Flat, Philips, 5/16" Hex. Nut
- Additional fasteners depending on surface
- Shims
- Hand Saw/Power Saw

4.5 Suggested Fasteners for Frame

- #14 x 2-2/3" (70mm) long sheet metal screws for wood.

4.6 Suggested Fasteners for Door

- #12, #14, Wood screws, Sheet Metal screws, Self-tapping screws of varying lengths depending on applications.
- Typically, doors are hung on 4 1/2" (114mm) butt hinges or 3/4" (19mm) offset pivots.

The fastener components listed above are merely suggestions. A technician should use their best discretion to determine what components they will need to complete the job.

Section 5.0 - Operator Installation

The following information gives a complete guidance to the correct installation on the SW800 operator.

5.1 Control Unit

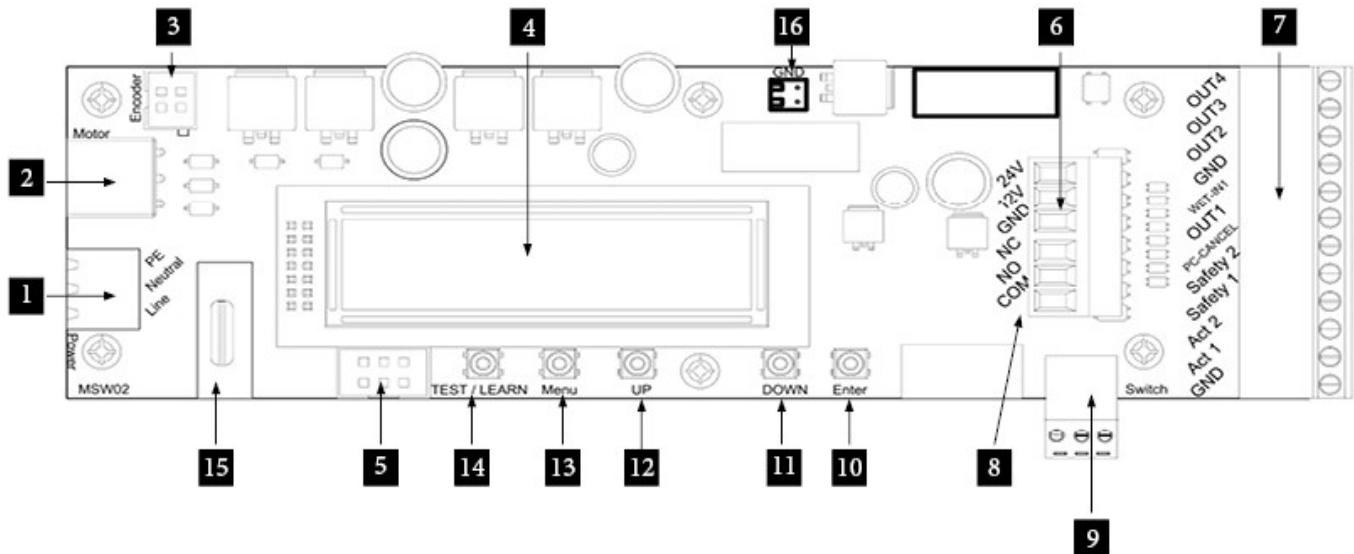

No.	Description	No.	Description
1	Power Unit (90-250VAC 50/60hz)	9	3 Position Switch Input Connector
2	Motor Connector Plug in	10	Enter Button
3	Motor Encoder Connector Plug in	11	Down Button
4	LED Display Screen	12	Up Button
5	Sync/Comm Connector Plug in (Double Operator)	13	Menu Button
6	24VDC/12VDC Power Output Connector	14	Test/Learn Button
7	Activation/Safety Accessories Connector	15	Fuse - Replaceable
8	E-Lock Signal Connector	16	Battery Back-up Connection

5.2 Operator Handing and Orientation

Verify that the operator is the correct orientation. Left Push, Right Push, Left Pull, or Right Pull.

Note:

- If the operator label is facing 'Down' to the floor, the handing is Left Hand Push/Pull.
- If the operator label is facing 'Up' to the ceiling, the handing is Right Hand Push/Pull.

5.3 PUSH Arm Handing and Operator Orientation

RHR/LEFT Hand PUSH

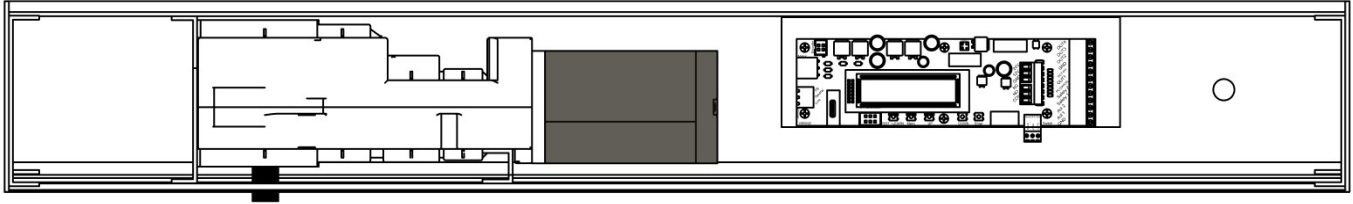

LHR/RIGHT Hand PUSH

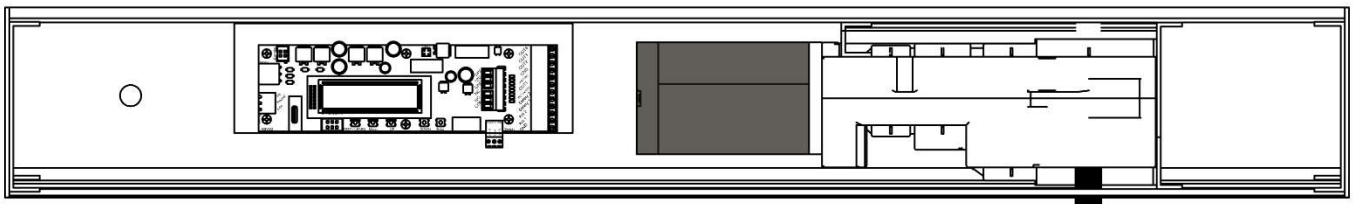

5.4 PULL Arm Handing and Operator Orientation

LEFT Hand PULL

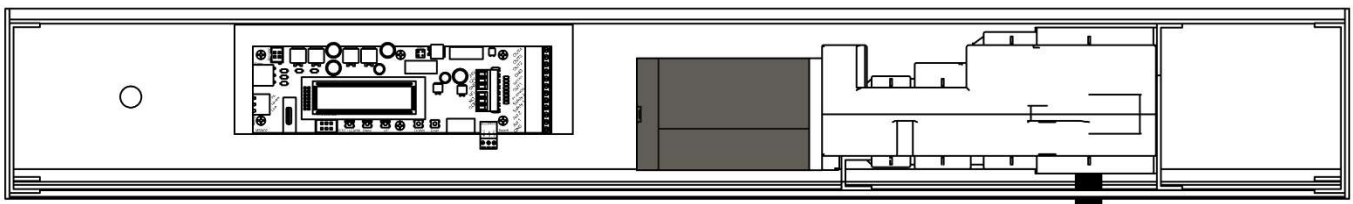

RIGHT Hand PULL

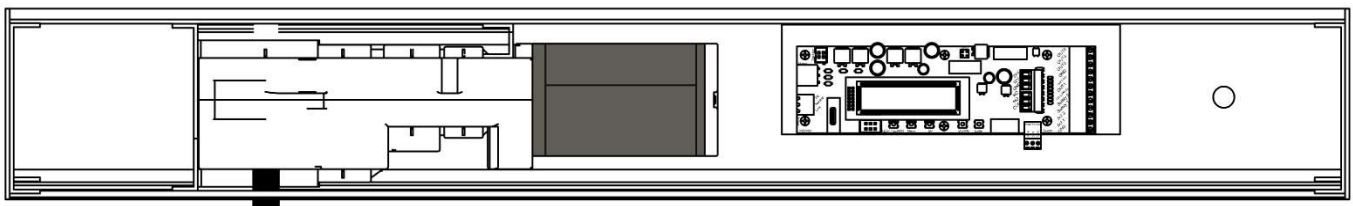

5.5 Operator Installation

Step 1. Remove the cover from the assembly by gently pulling the cover down with minimal effort. Carefully set the cover in a location where it will not be damaged.

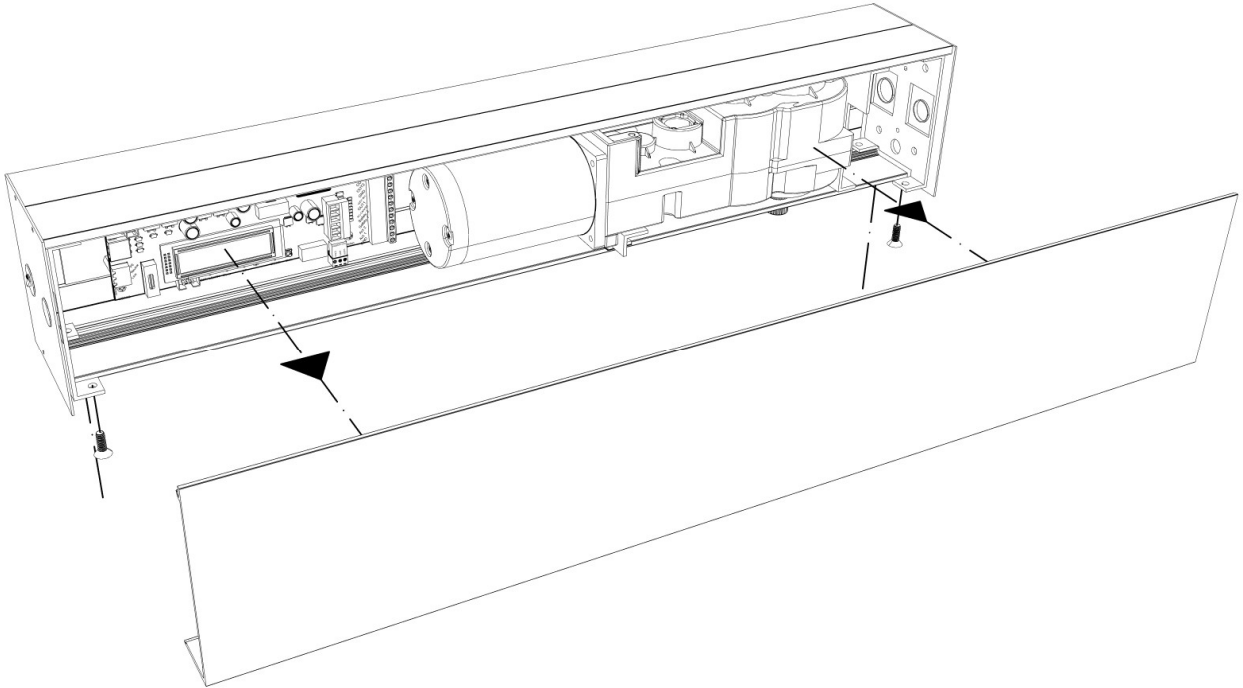

Step 2. Remove the motor/gear box and control board from the back plate, make through holes on the back plate for mounting header where appropriate.

Note: Can be installed without removal of motor/gear box and control board if preferred.

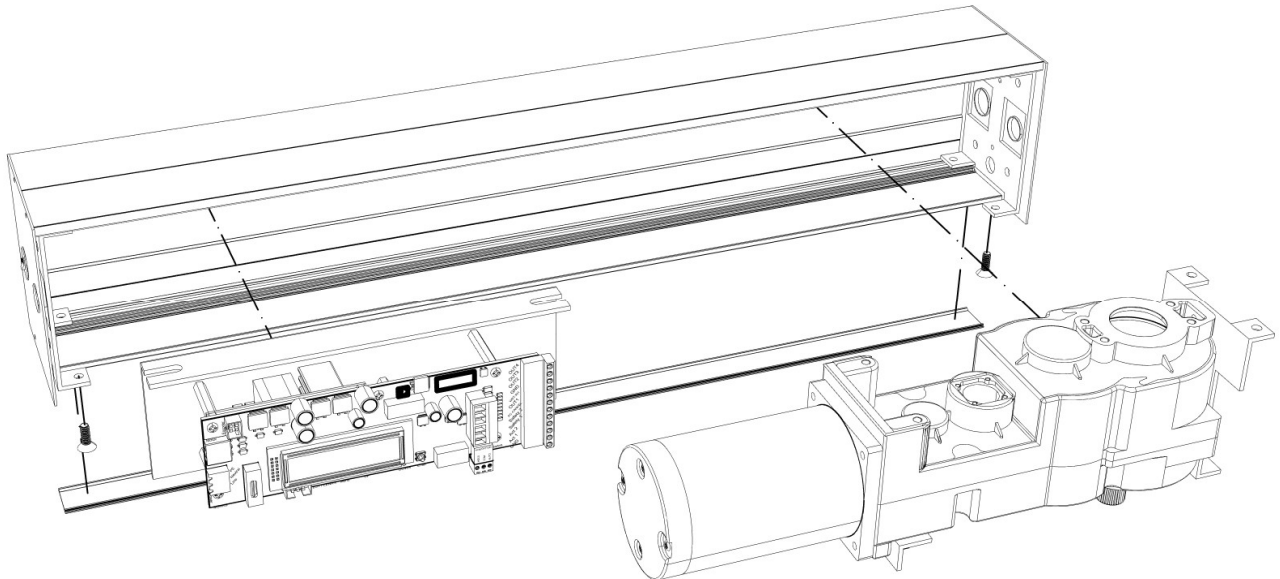

Step 3. Power Supply

Make sure all power is turned OFF before handling the supply wires. This should be done by a certified electrician and within the guidelines of the enforced local electrical codes.

Drill holes for the high voltage wires in backing plate.

Pull the power supply into the header at the same time as the header assembly is positioned.

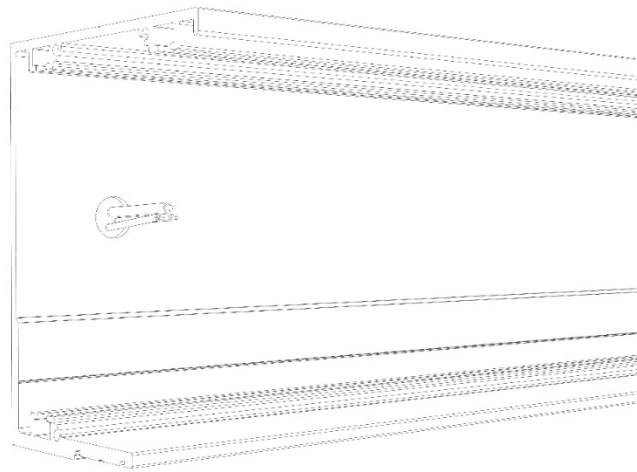

Step 4. Fixing Operator in Place

Be sure there is proper support in the wall to secure the header at the vertical jambs and behind the header at intervals between the vertical jambs

A solid space material or filler may be required to compensate for any gap between the back of base rail and wall.

Ensure, before fixing base rail to the door frame, that access holes for power supply cables are in line, if required.

Secure the header box to the top of the door frame with the appropriate fasteners.

Holes can be made anywhere in header to secure. All holes MUST be drilled into substantial support (studs, blocks, framing, etc.).

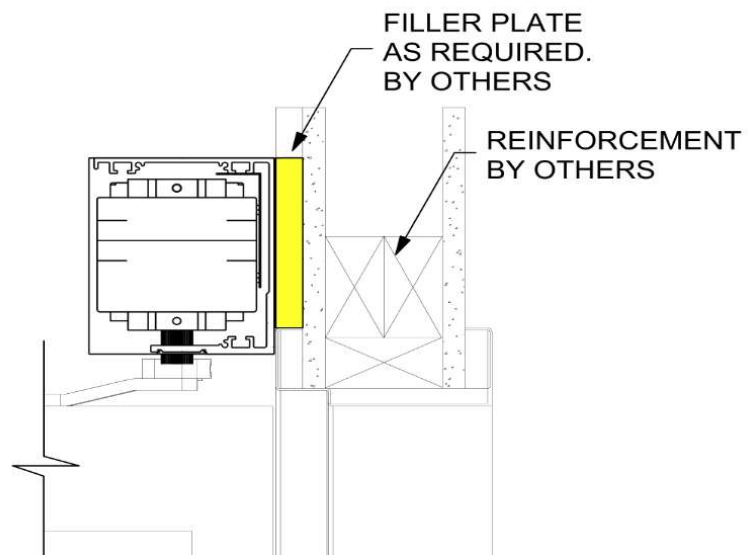

Step 5. Once the header back plate is in place, install the motor/gearbox and control board to the header back plate.

Slide the nuts (supplied with the operator) to hold the motor/gearbox and control board along the 2 parallel tracks on the back plate.

Fasten the bolt to hold the motor/gearbox and control board in place.

The motor/gearbox needs to be installed so that the center of the spindle is 6" (152mm) from the end of the plate, for units produced after August 1, 2022. For units produced before August 1, 2022, the spindle was set at 4 ¾".

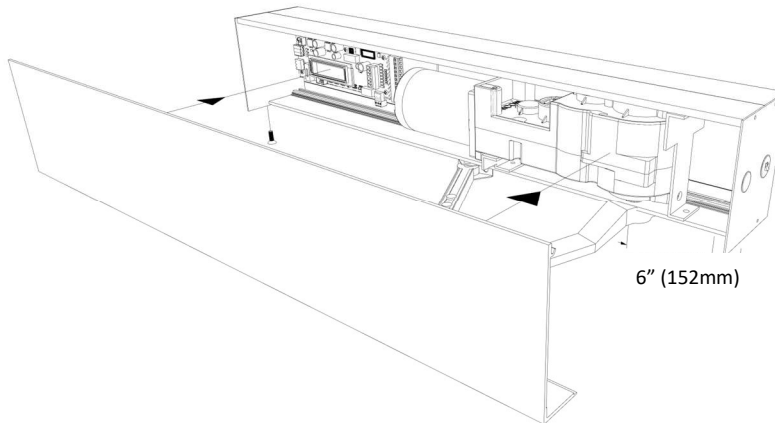

Section 6.0 - Push and Pull Arms Installation

Following these simple steps will allow the door to be set up quickly and correctly. Refer to installation drawings below.

6.1 Push Standard Scissors Arm for 0" - 14" Reveals

Note: Base rail to be mounted flush with the bottom of the door frame.

A solid spacer material or filler may be required to compensate for any gap between the back of base rail and wall. Ensure, before fixing base rail to the door frame, that access holes for power supply cables are in line, if required.

Step 1: With door closed, attach shoe of the arm to the door panel @ 13" from hinge edge. Fig. 1.

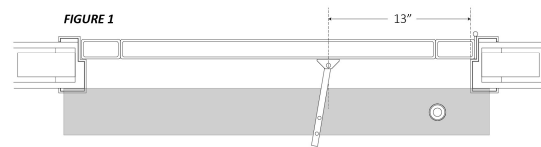

Step 2: Install power section of the arm to the spindle on the operator @ 85°-90° from the hinge side. Fig. 2.

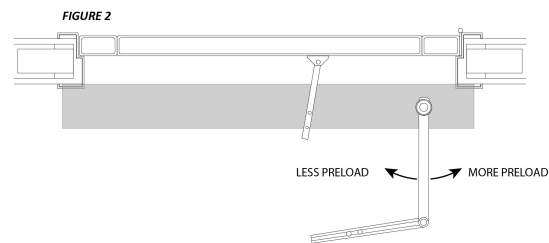

Step 3: Rotate the attached arm from the above 85°-90° to about 110° from the hinge side. Fig. 3.

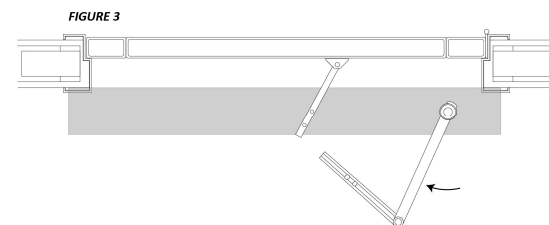

Step 4: Align and connect both the arms of the shoe and power section. Slide the adjustable track together and tighten the screws. Fig. 4.

Increase or decrease spring pre-load by rotating the power section arm while attaching to the spindle. Fig. 2.

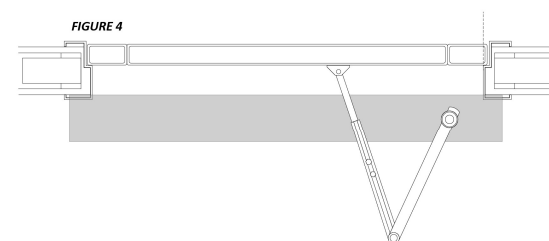

Step 5: Press TEST/LEARN button to begin the learning cycle. See *Learning Door Cycle*.

6.2 Pull Standard Angle Arm With Track for 0" to 4" Reveals

Notes: Operator to be mounted so that base of drive shaft is clear above the door top. See Installation Drawings. A solid spacer material or filler may be required to compensate for any gap between the back of base rail and wall. Ensure, before fixing base rail to the door frame, that access holes for power supply cables are in line, if required.

Step 1. Without PULL arm fitted, set 3-position switch to Hold Open (II). The drive shaft will turn fully until hitting the in-built fixed doorstop, so charging the spring.

Step 2. Manually open the door to full Step 2. Manually open the door to full open (approx. 100° open position).

Fit PULL arm to the drive shaft at the full open position so the roller touches the door.

Mark the open position where roller touches the door.

Step 3. Set 3-position switch to manual (0) and allow the door to close under spring power.

Mark the closed position where the roller touches the door.

Step 4. Position slide track horizontally within 1st and 2nd mark, then fix it to the door.

Slide the roller along the channel, followed by fitting end caps.

Step 5. Turn 3-position switch to automatic (I). Press Test/Learn button to begin the learning cycle. See Learning Door Cycle.

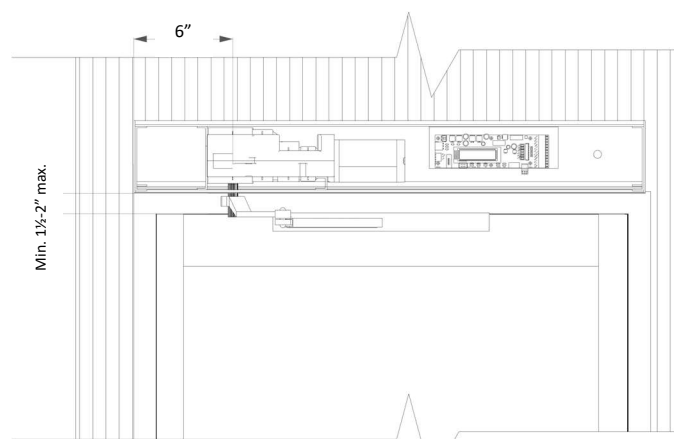
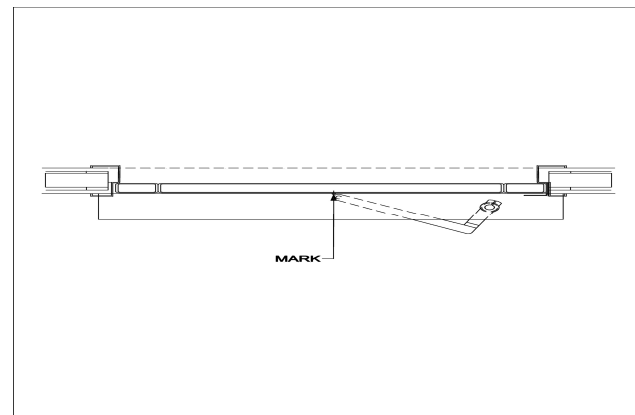
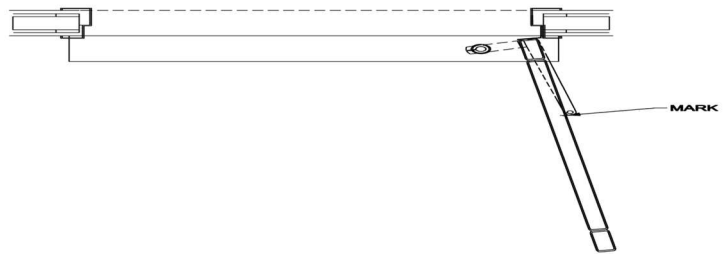

THIS PAGE INTENTIONALLY LEFT BLANK

Section 7.0 - Learning Cycle and Start Up

"TEST/LEARN" button is currently used for two functions.

- a. **TEST** - if the "TEST/LEARN" button is pressed for less than 3 seconds and released, an activation will be generated.
- b. **LEARN** - if the button is pressed for at least 4 seconds and released, a door re-learn is selected.

Re-learn is confirmed by pushing the "ENTER" button.

Re-learn can be cancelled by pushing the "TEST" or "MENU" or "UP" or "DOWN" button.

Step 1. Place a heavy item or your foot at the desired full open position at approx. 90° open position.

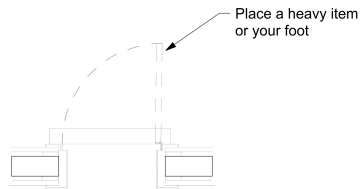

Step 2. Press Test/Learn button for 3 seconds and release to begin the learning cycle.

Step 3. Incorporating a unique electronic stop, the door will learn the full open position during a one-time open/door cycle.

The door will open until it touches the object at the desired full open position.

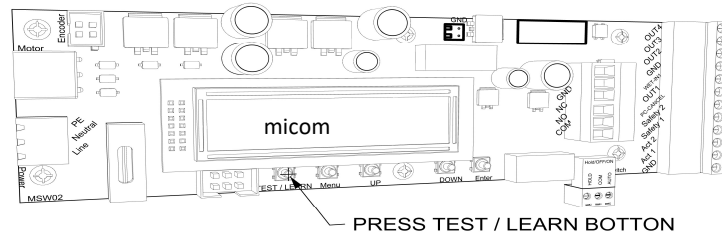

Back-check and latching position are automatically calculated and do not need setting (unless adjustment is required).

On the next activation, the door will open, slow at back check, then stop at the learnt opened position.

The door will not hit the in-built fixed doorstop.

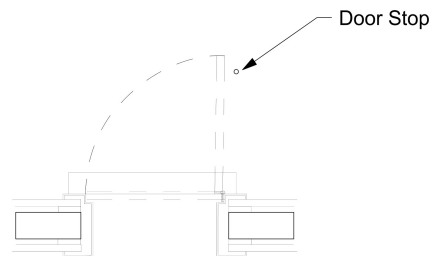

Note: The built-in mechanical doorstop should only act as a limiting device should the door be pushed past its pre-set electronically selected open position.

Section 8.0 - Electronics Controller Programming

- Programming is quick and simple via the visual LED display.
- Each FUNCTION is clearly shown on the display in text, words, and symbols.
- The VALUE or APPLICATION can easily be adjusted using the buttons on the face of the controller.
- Changed menu values will automatically be saved during the next opening cycle.



SPECIAL WARNING

All Menu Values and Settings must comply with ANSI/BHMA A156.19 Standard for Power Assist and Low Energy Power Operated Swing Doors.



8.1 Opening Speed (05-12 for Low energy) or (05-20 for Full Automatic)

- This setting is the door "Opening" speed from the fully closed position to the back-check position.
- Use the "UP" and "DOWN" buttons to select the desired door opening speed.
- Active the door to check the speed is correctly adjusted.

8.2 Back-check Speed (01-05)

- This setting is speed when the door reaches the back-check position to the full door opening.
- Use the "UP" and "DOWN" buttons to select the desired door back-check speed.
- Activate the door to check the speed is correctly adjusted.

8.3 Safety Speed (Hold/Crawl)

- This setting is door speed when "Safety 2" is active during the opening cycle.
- Use the "UP" and "DOWN" buttons to select either Hold or Crawl speed.

8.4 Closing Speed (01-15)

- This setting is the door "closing" speed from the fully opened position to the Latch area.
- Use the "UP" and "DOWN" buttons to select the desired door "Closing" speed.
- Activate the door to check the speed is correctly adjusted.

8.5 Latch Speed (01-05)

- This setting is the door "Closing" speed in the Latch area until fully Closed.
- Use the "UP" and "DOWN" buttons to select the desired door "Latching" speed.
- Activate the door to check the speed is correctly adjusted.

8.6 Current Limit (01-20)

- In case the door encounters an obstruction during the Opening cycle, once the maximum Current limit is reached for at least 2 seconds, the door Opening is then cancelled.
- Use the "UP" and "DOWN" buttons to select the desired "Current" limit strength.
- Activate the door to Open. During the Opening cycle, physically apply pressure to stall the door for at least 2 seconds.
- Check the force needed to reach the limit at which the door Opening is cancelled.
- Increase or Decrease this setting to achieve the correct strength needed.
- *Note: Setting of 10 is sufficient for most all applications.*

8.7 Activation Time (01-60 seconds)

- This setting is the duration of the door Open cycle in seconds.
- The timer starts when the door starts to activate.
- Use the "UP" and "DOWN" buttons to select the desired "Opening" time.

8.8 Hold On Manual Open (No or 01-05 seconds)

- This setting is the length of time the door will be physically held Open, when the door is "Manually" pushed or pulled open by a pedestrian.
- The door must be opened at least 60% of the door swing for this feature to activate.
- Use the "UP" and "DOWN" buttons to Enable or Disable this feature and set the timer value to keep open.
- Caution: Do not set timer for more than 1.0 seconds unless requested by the end user.

8.9 Electronic Door Stop (Yes/No)

- This feature is always Enabled even if you select Disabled.

8.10 Electric Lock (Yes/No)

- This setting is to Enable or disable the electric Lock/Strike through the Control unit.
- Select No when there is not an electric Lock.
- Use the "UP" and "DOWN" buttons to set the proper Electric Lock.

8.11 Electric Lock Delay (0.2-2.0 seconds)

- This setting is the length of time in seconds for the Delay between activating the Electric Lock and the Start of the Opening cycle.
- Use the "UP" and "DOWN" buttons to Disable or Enable the electronic Delay/Output.
- Note: Setting of 0.2 seconds is sufficient for most applications.

8.12 Latch Position (2%-30%)

- This setting will adjust the door Latch position during the Closing cycle.
- Use the "UP" and "DOWN" buttons to set the starting point for the Latch position.
- Activate the door. During the Closing cycle, check the Latch starting position where the door begins to slow down.
- Check this setting is correctly adjusted.
- If stack pressure is preventing the door from Fully Closing, set at 30% and activate the Power Close feature.

8.13 Back-check Position (70%-98%)

- This setting is to adjust the door Back-check position of the Opening cycle.
- Use the "UP" and "DOWN" buttons to set the starting point for the Back-check position.
- Activate the door. During the Opening cycle, check the position where the Back-check begins and the door starts to slow down.
- Check this setting is correctly adjusted.
- In windy conditions, set to 70%.

8.14 Push & Go (Yes/No)

- This setting is to Enable or Disable the Push & Go feature, also known as Manual Activation, when the door is Manually pushed or pulled open by hand.
- Caution: Do not activate this feature without training and specifically requested by the end user.
- Use the "UP" and "DOWN" buttons to Disable or Enable this feature.

8.15 Push & Go Active Time (01-30 seconds)

- This setting is to adjust the duration of the door Open cycle in seconds from when the door is Manually pushed Open to when the Push & Go feature is enabled.
- Use the "UP" and "DOWN" buttons to select the desired Opening time.

8.16 Power Close (Yes/No)

- **WARNING: You should always install a Presence Safety sensor when Enabling this feature.**
- This setting is to Enable or Disable the Power Close Assist feature.
- When Power Close is "ON", should the door reach the Latch position and cannot fully Close after 3 seconds, the motor will assist the spring in order to fully Close the door.
 - ▶ *This feature is used when the pressures on the door prevent the door from fully Closing*
- Use the "UP" and "DOWN" buttons to Enable or Disable this feature.

8.17 Power Close Force (01-05)

- This setting will allow you to increase or decrease the amount of Closing Force needed to fully Close the door at the Latch position.
- This feature is used to counter act Stack or Wind pressures.
- **IMPORTANT:** When using the Power Close Force feature, we strongly recommend to wire a Presence Safety sensor into the input (PC Cancel" on the control board terminal that Cancels out this feature when a pedestrian presence is detected. PC = Power Close.
- Use the "UP" and "DOWN" buttons to select the desired Closing Force. Use the lowest Force setting needed to ensure positive Latching in these conditions.
- Check this setting is correctly adjusted.

8.18 Door Seal (Yes/No) Not an Active Function.

8.19 Special Function Normal (Access/Access→Activate).

- This setting is used for Access Control options, including Electric Strikes/Locking devices.
- This requires a Wet Input connection to Open. A Wet Input will activate the Strike/Lock and open the door simultaneously.
- Use the "UP" and "DOWN" buttons to select from Normal, Access or Access→Activate.
 - ▶ Normal = default settings.
 - ▶ Access = only the Strike/Lock will release and the exterior "ACT2" button turns on, so the pedestrian will need to perform a "Knowing Act" for the door to Open.
 - ▶ Access→Activate = door and Strike/Lock activate simultaneously when a validated credential is presented.

8.20 In1 Wet Input (Normally Opened/Normally Closed)

- This feature is used with the "Special Function" feature above for external Access Control options that are either Normally Open or Normally Closed (NO/NC) using the Wet-IN1 input terminal on the board.
- Typical Access Control devices are: Key Pads, Card Readers, Proximity Cards, etc.
- Use the "UP" and "DOWN" buttons to select the NO/NC circuit required by the Access Control device.
- Normally Open = Access Control device will send 12/24vdc power to the control unit.
- Normally Closed = Access Control device takes the 12/24vdc power away from the control unit.

8.21 This Door Overlaps (Yes/No)

- This is used for a Double door operator application when there is a door overlap.
- This setting will Enable or Disable the Double swing door Co-ordinate feature.
- Use the "UP" and "DOWN" buttons to Enable or Disable this feature.

8.22 Factory Reset (Yes/No)

- This setting will Restore the control unit to its original Factory settings, all current settings will be lost.
- To reset the control to the original settings, push the "UP" button, then push "ENTER" button to confirm.
- You will need to reprogram all features and settings of the control unit.

8.23 Display Light On Time (01-30 minutes)

- This feature sets the length of time in minutes the LED display will remain on after the last button has been pushed on the control unit.

8.24 Operator Type (Low Energy/Full Automatic)

- This setting is used to select which type of Operator functionality you want for this application.
- **WARNING: The "Full Automatic" mode can NOT be selected unless all requirements of this installation complies with the ANSI/BHMA A156.10 Standard for Power Operated Pedestrian Doors including, but not limited to, Safety Sensors and Guardrails.**
- Use the "UP" and "DOWN" buttons to select.

8.25 Safety 2 Inhibit at (30%-98%)

- Safety 2 will be deactivated at the point where the Safety sensor would pick up a wall or fixed object adjacent to the door.
- This setting will inhibit the Safety Sensor (back side of the door) in order to allow the door to fully open.

8.26 Out 1 Function (Door closed/Stairway Fan Out)

- Door Closed = sends a signal when the door is Closed.
- Stairway Fan Out = sends a signal when the door is Open.
- Use the "UP" and "DOWN" buttons to select the setting.

8.27 Pull Before Open (Yes/No)

- This setting will Pull/Push the door closed for a fraction of a second before the activation to open the electric strike.
- Give a clear Opening once the Strike/Lock has been released.
- **Caution:** Set the electric Lock Delay to a minimum of 0.2 seconds.

8.28 Reverse on Obstruction (Yes/No)

- This setting will Enable or Disable the Re-activation feature.
- If Enabled, the Re-activation is generated if the door encounters an obstruction for at least 2 seconds during the Closing cycle, between the Back-check and the Latch areas.
- Use the "UP" and "DOWN" buttons to Enable or Disable this feature.

8.29 Power Shut (Yes/No)

- **WARNING:** You should always install a Presence Safety sensor when Enabling this feature.
- This setting is to Enable or Disable the Power Shut feature.
- When Power Shut is "ON", the motor will assist the spring driving the door during the Closing cycle from a 90° Open position to the fully Closed position.
 - ▶ This feature is used when the application is exposed to constant high winds conditions that prevents the door from Closing properly and smoothly.
- Use the "UP" and "DOWN" buttons to Enable or Disable this feature.

8.30 Power Shut Force (01-05)

- This setting will allow you to increase or decrease the amount of Closing Force needed to fully Close the door from the 90° position to fully closed position.
 - ▶ *This feature is used to counteract High Wind conditions.*
- **IMPORTANT:** When using the Power Shut Force feature, you must connect a Presence Safety sensor into the input "PC Cancel" on the control board terminal that Cancels out this feature when a pedestrian presence is detected. PC = Power Close.
- Use the "UP" and "DOWN" buttons to select the desired Closing Force. Use the lowest Force setting needed to ensure positive Latching in these conditions.
- Check this setting is correctly adjusted.

8.31 Software Version MSW01 v. X.XX

- This menu will display the Software version in the Control unit where X equals a numeric value.
- The month and year of the Control manufacturing date will be displayed.

Basic Settings Table describing the Controls Functions, Settings, Values and Defaults

All values and settings must comply with ANSI/BHMA A156.19 Standard for Power Assist and Low Energy Power Operated Swing Doors.

No.	FUNCTION DESCRIPTION	SETTING	VALUE	DEFAULT
1	OPENING SPEED Door opening speed from full closed to back check position	5 to 20	5 sec = slowest 20 sec = fastest	10
2	BACK CHECK SPEED Door speed at final section of opening	1 to 5	1 sec = slowest 5 sec = fastest	3
3	SAFETY SPEED Slow speed (crawl) or stop (hold) when Safety1 is active	2 steps	HOLD/CRAWL	HOLD
4	CLOSING SPEED Door closing speed from full open to latch position	1 to 15	1 sec = slowest 15 sec = fastest	5
5	LATCH SPEED Door speed at final section of closing	1 to 5	1 sec = slowest 5 sec = fastest	1
6	CURRENT LIMIT Obstruction detection	1 to 20	1 sec = more sensitive 20 sec = less sensitive	10
7	ACTIVATION TIME Time begins at activation signal ON	1 to 60	1 sec = minimum 60 sec = maximum	5
8	HOLD ON MANUAL OPEN Door held open when pushed by hand. Not active with push & go	2 options	A = No B = 5 steps (1-5 sec)	No
9	ELECTRIC DOOR STOP Setting stop position by encoder	2 options	Y = Yes N = No	Yes
10	E-LOCK Strike or Electromagnetic Lock	2 options	Y = Yes N = No	No
11	E-LOCK DELAY Time before E-Lock will release	18 steps: 0.2 sec to 2.0 sec	0.2 sec = minimum 2.0 sec = maximum	1.0
12	LATCH POSITION Position at which final section of closing begins	15 steps: 2% to 30%	2% = minimum 30% = maximum	10
13	BACK CHECK POSITION Position at which final section of opening begins	15 steps: 70%-98%	70% = maximum 98% = minimum	80
14	PUSH & GO	2 options	Y = Yes N = No	No
15	PUSH & GO ACTIVE TIME Time door is pushed open before activation	30 steps	1 sec = minimum 30 sec = maximum	3

No.	FUNCTION DESCRIPTION	SETTING	VALUE	DEFAULT
16	POWER CLOSE Power assisted closing with spring	2 options	Y = Yes N = No	No
17	POWER CLOSE FORCE	1-5 steps	1 = minimum 5 = maximum	1
18	DOOR SEAL	NOT ACTIVE	N/A	N/A
19	SPECIAL FUNCTION Access Control WET Input from Strike/Lock	2 options	Access - Activated OFF Access - Activated ON	Normal
20	IN1 WET INPUT	2 options	NC = Normally closed NO = Normally open	NO
21	OVERLAP	2 options	Y = Yes N = No	No
22	FACTORY RESET	2 options	Y = Yes N = No	No
23	LIGHT ON TIME Time backlight remains on	30 steps	1 sec = minimum 30 sec = maximum	1
24	OPERATOR TYPE	2 options	FA = Fully Automatic HA = Low Energy	Low Energy
25	SAFETY 2 INHIBIT	2 options	No = Off Yes = On Yes = 34 steps	No
26	OUT1 FUNCTION	2 options	Door Closed - Door Closed Signal Stairway Fan Out - Door Open Signal	Door Closed
27	PULL BEFORE OPEN	2 options	Yes/No	No
28	REVERSE ON OBSTRUCTION	2 options	Yes/No	Yes
29	POWER SHUT	2 options	Yes/No	No
30	POWER SHUT FORCE	1-5 steps	1 = minimum 5 = maximum	2
31	SOFTWARE VERSION X.XX	N/A	Mgf. Date = Month and Year	N/A

Section 9.0 - Wiring Connections

9.1 On/Off/Hold Open Selector Switch - 3 position switch offers easy selection for 3 modes of operation:

1. Automatic - Motion sensors/push plates are active and will activate the operator to open the door automatically should they be triggered.
2. Off/Manual - The door is free to open by hand and will fully close with spring power. This function does not switch off the power; however, motion sensors/push plates are still active, but are ignored.
3. Hold Open - The operator will hold the door, in the fully open position, for an unlimited amount of time. The motor will not overheat or fail causing the door to close.

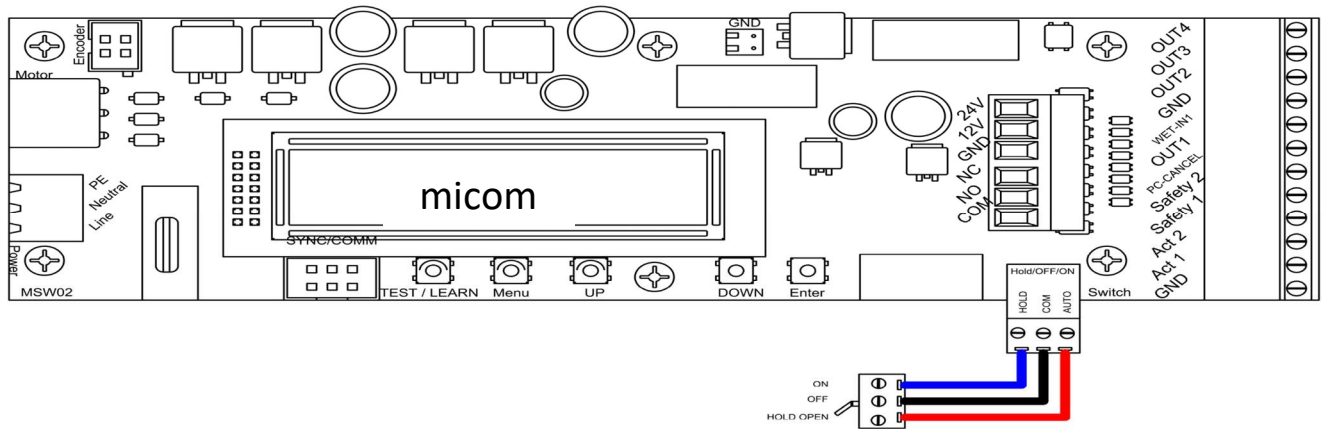

CAUTION: Wireless Activator devices must be 900MHz and higher frequency.

9.2 "Act1" - Activation 1

Connected to activation switch such as motion sensor or push plate. When activated, this signal always opens the door.

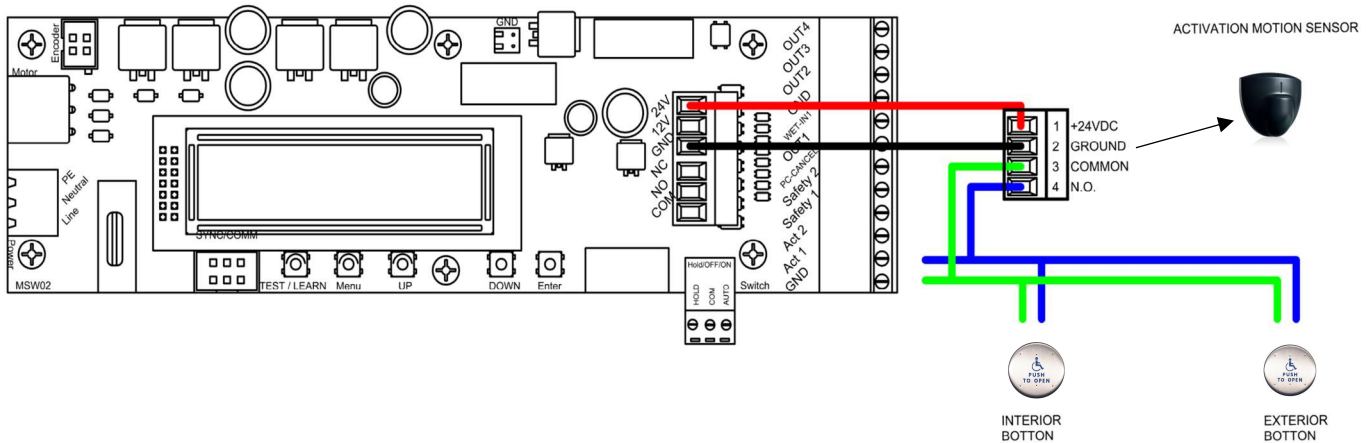

9.3 "Act2" - Activation 2

Act2 serves only as a second activation device and requires an activation device be connected to the Act1 terminal. Act2 only becomes active after Act1 is triggered or when the door is closing and before reaching the latch position.

9.4 Safety 1

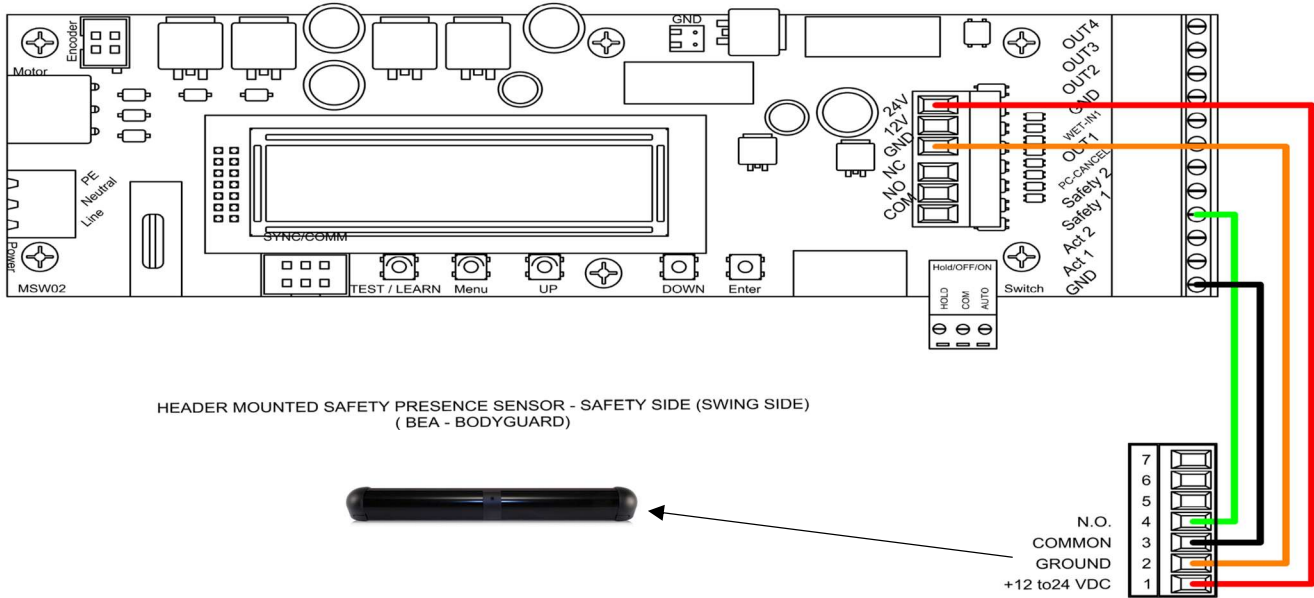

9.5 Safety 2 Full Automatic Set-up

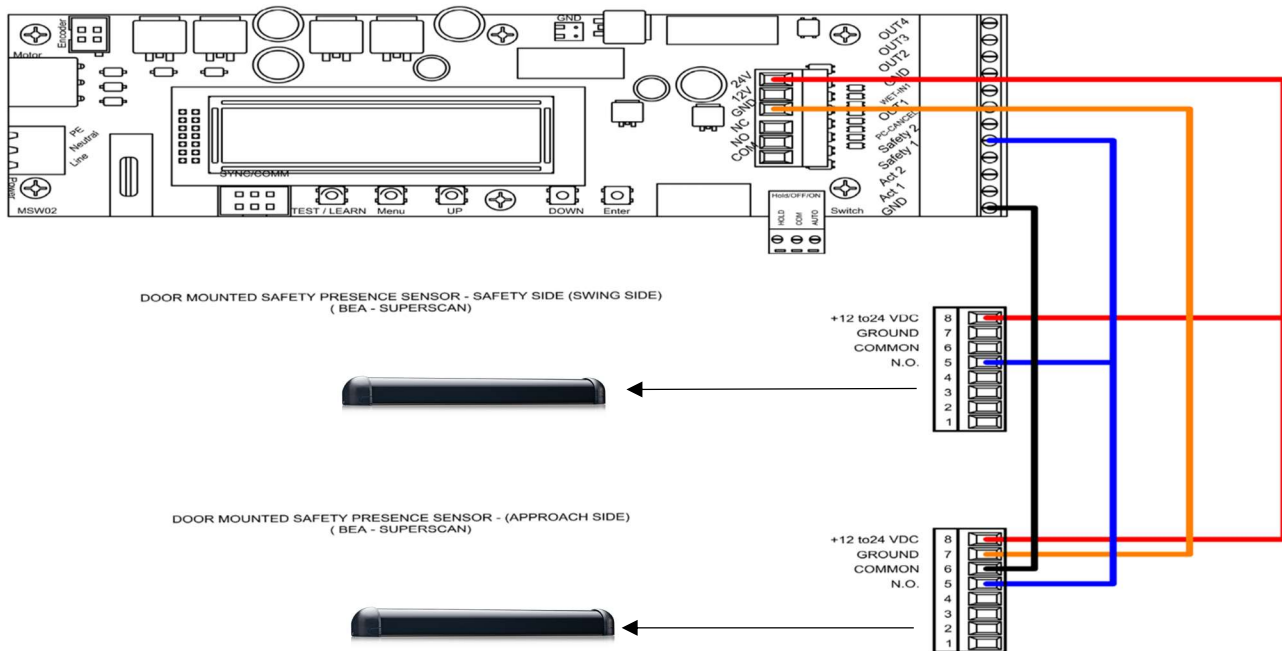

THIS PAGE INTENTIONALLY LEFT BLANK

Section 10.0 - Changing Handing of Operator

Step 1. Invert the entire operator assembly 180°

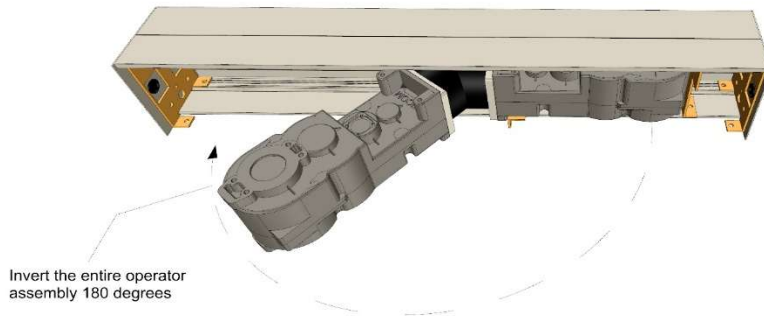

Step 2. Remove drive shaft (spindle) from motor gearbox assembly (See changing position of drive shaft)

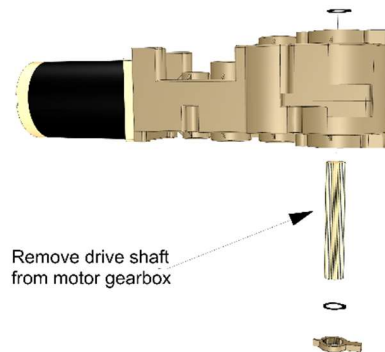

Step 3. Re-attach drive shaft (spindle) to the opposite side of motor gearbox assembly.

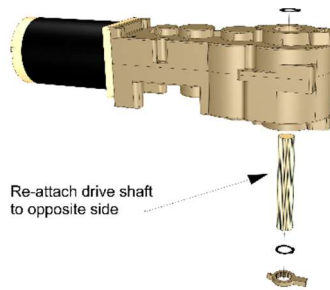

Step 4. Detach wire connections from operator to control board

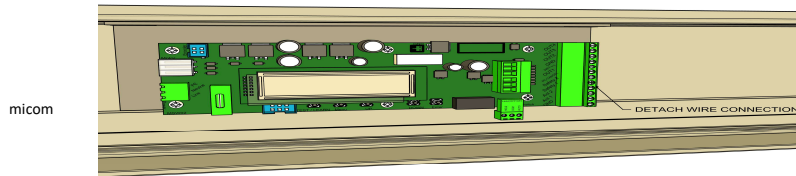

Step 5. Remove control assembly from the base and rotate 180 degrees.

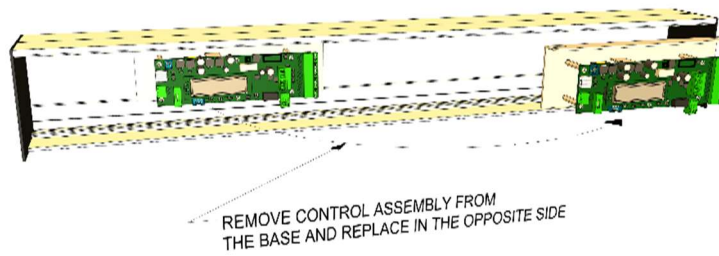

Step 6. Replace control and socket screws.

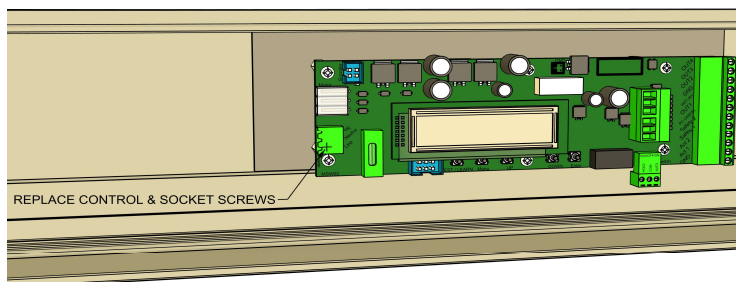

Step 7. Connect wire harness

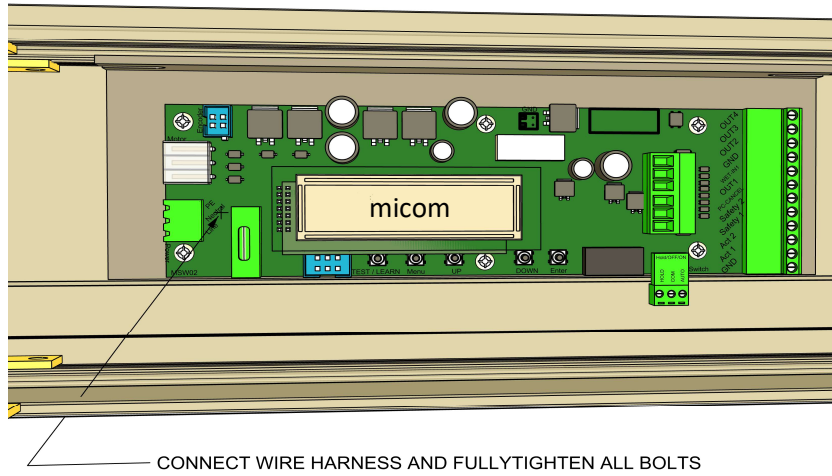

Step 8. Insert Spline shaft on the operator (depended on push or pull application and spindle rotation)

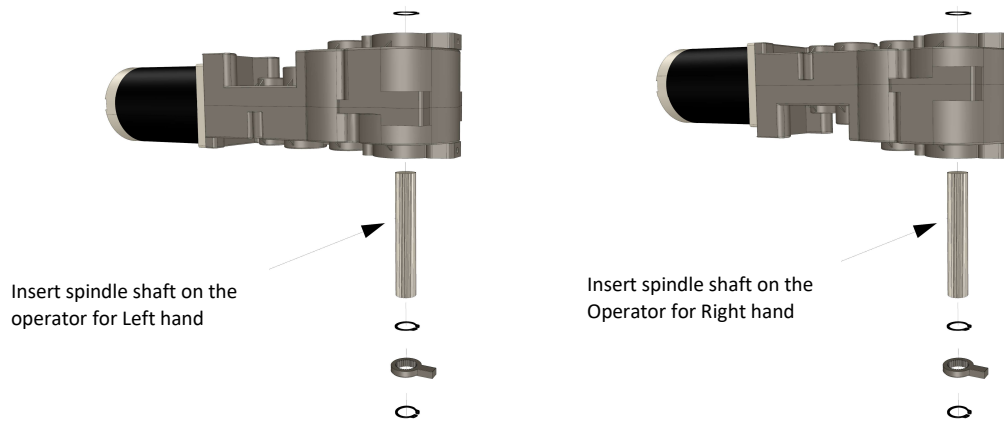

THIS PAGE INTENTIONALLY LEFT BLANK

Section 11.0 - Safety Signage and Decals

The center of the decal height should be located at 50" +/- 12" (1270 +/- 305 mm) above the finished floor.

See ANSI standard A156.19 requirements for additional safety decal information.

Check Local and State codes for additional signage requirements to ensure full compliance.

The center of the push plate height should be between 34" (864 mm) and 48" (1,219 mm) above the finished floor.

LOW ENERGY DECALS

(ON BOTH INGRESS AND EGRESS SIDES)

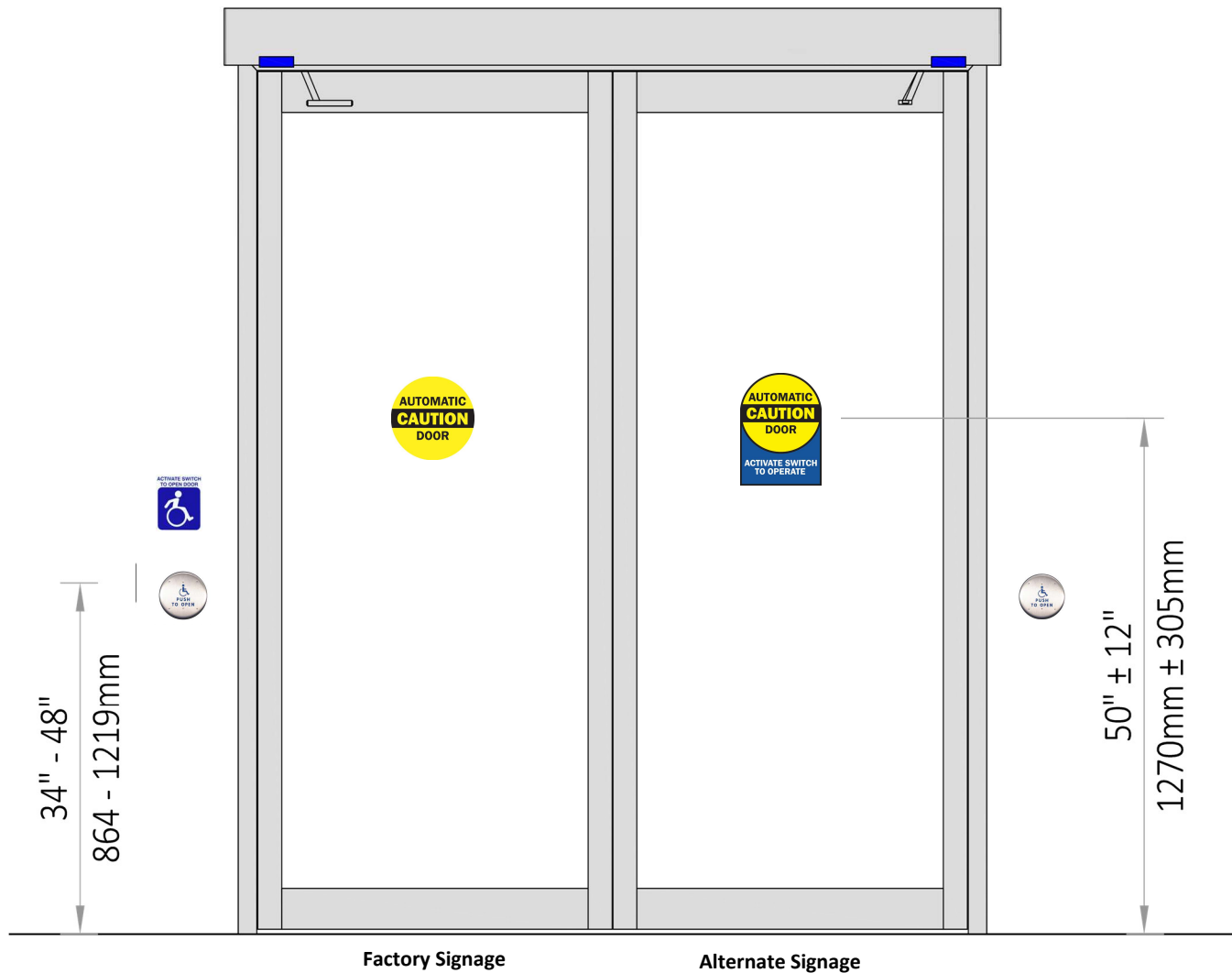

Factory Signage includes the round Yellow/Black and the rectangular Blue/White decals with the operator.

- This is compliant with ANSI A156.19 standard

Alternate Signage is a popular alternative that some building owners prefer to better integrate with the aesthetics of the building. See installer for other options.

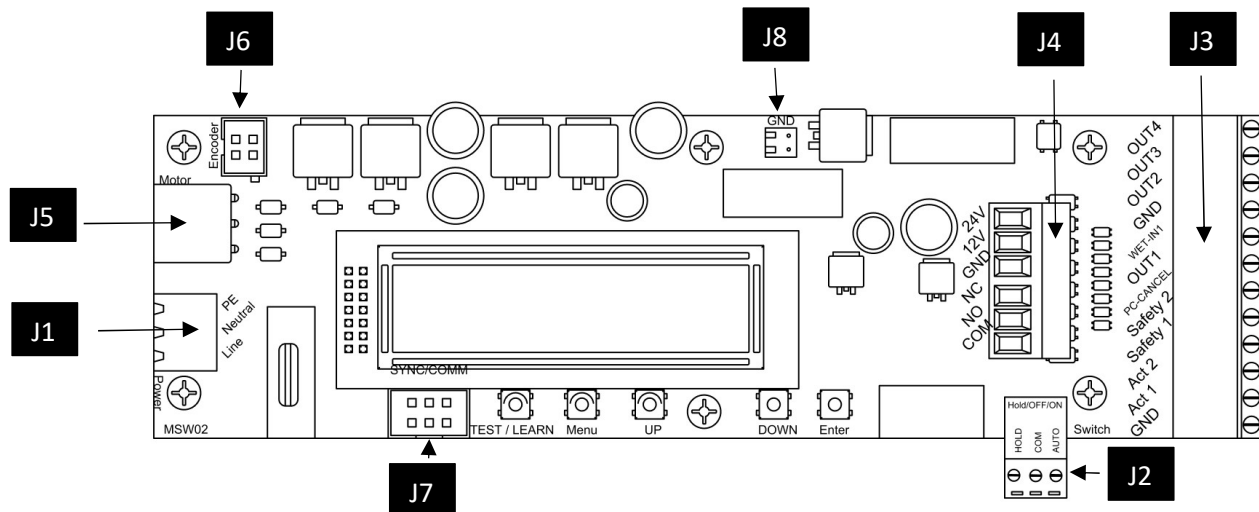

J1 - Connector Description: Power input 100-240VAC (100W max.)

PIN	Definition
J1.1	AC Ground
J1.2	AC Neutral
J1.3	AC Line (Fused)

J2 - Connector Description: Hold open/OFF/Auto switch input

PIN	Definition
J2.1	Auto signal - This signal (to GND) will allow activation
J2.2	GND - Ground reference for signal and power
J2.3	Hold Open - This signal (to GND) will activate the operator to hold the door open.

J3 - Connector Description: Accessories and Sensors Inputs and Outputs

PIN	Signal	Definition
J3.1	GND	Ground reference for signal and power.
J3.2	ACTIVATION 1	(Input) This signal (to COM) will activate the operator. If "AUTO" signal (J2.3) is to COM and no current fault is present.
J3.3	ACTIVATION 2	(Input) This signal (to COM) will activate the operator. (If "AUTO" signal (J2.3) is to COM with no current fault present and door is not fully closed.
J3.4	SAFETY 1	(Input) When the door is fully closed, this signal (to COM) will prevent an activation. When the door is fully opened, this signal (to COM) will prevent the door from entering the closing cycle.
J3.5	SAFETY 2	(Input) When the door is fully closed, this signal (to COM) will prevent and activation. When safety signal clears, pending activation will activate the operator. During the opening cycle, the door will go to safety (Hold) speed. (When the signal is to COM). When the door is fully opened, this signal (to COM) will prevent the door from entering the closing cycle.
J3.6	PC CANCEL	(Input) This signal (to COM) will prevent or cancel power close.
J3.7	OUT1 DOOR CLOSED	(Output) This signal is tied to COM when door is fully closed. Door must be set up (Learning Completed).

J3 - Connector Description (continued)

PIN	Signal	Definition
J3.8	IN1	(Input) Not used.
J3.9	GND	Ground reference for signals and power.
J3.10	OUT2	(Output) Not used.
J3.11	OUT3	(Output) Not used.
J3.12	OUT4	(Output) Not used.

J4 - Connector Description: Sensor power and electric lock outputs

PIN	Definition
J4.1	(Output) + 24 VDC (500mA Max)
J4.2	(Output) +12 VDC (1,000mA Max)
J4.3	(GND) Ground reference for signals and power.
J4.4	(Output) Electric lock relay N.C. (Normally Closed)
J4.5	(Output) Electric lock relay N.O. (Normally Open)
J4.6	(COM) Electric lock relay common

J5 - Connector Description: Motor output (isolated from power input)

PIN	Definition
J5.1	Motor Positive
J5.2	Motor Negative
J5.3	AC Ground

J6 - Connector Description: Motor encoder

PIN	Definition
J6.1	(Output) +5 VDC
J6.2	(Input) Encoder Signal B
J6.3	(Input) Encoder Signal A
J6.4	COM (Ground)

J7 - Connector Description: ISP/SNYC/Communication

PIN	Definition
J7.1	(Output) PDO
J7.2	(Output) +5 VDC
J7.3	(Output) SCK
J7.4	(Input) PDI
J7.5	(Input/Output) RST
J7.6	COM (Ground)

J8 - Connector Description: Battery Back-up Charger

PIN	Definition
J8.1	Ground
J8.2	(Output) 24 VDC

Section 13.0 - Daily Safety Checklist

The best time to perform a Daily Safety Check is early in the morning while pedestrian traffic is still restricted from Sensor activating zones. The purpose of a Daily Sensor Check is to ensure pedestrian safety and Owner protection.

CAUTION

If the Swing Door will not be used for at least 1 month, it is recommended to turn power OFF to the Unit.

CAUTION

In order to guarantee reliability of the installation, any components showing signs of wear must be replaced as a preventative measure.

CAUTION

If a Sensor is not working, the door may swing towards you without stopping.

ATTENTION: In the event any type of object needs to be removed from the Sensor Safety Zone (vicinity), the Sensor must "relearn" the zone before resuming normal operations. Relearn may take a 1-2 minutes.

1. Ensure the Power Breaker is switched ON. Do not switch Power Breaker On and OFF too quickly.
2. Ensure the (On/Off/Hold Open) Rocker switch is set to "ON."
3. Activate the Swing Door.
 - ▶ Door should open at a slow, smooth pace (4 or more seconds), and stop without impact.
 - ▶ Door must remain fully open for a minimum of (5 seconds) before beginning to close.
 - ▶ Door should close at a slow, smooth pace (4 or more seconds), and stop without impact.
4. Inspect the floor area. It should be clean with no loose parts that might cause user to trip or fall. Keep traffic path clear.
5. Inspect door's overall condition. The appropriate signage should be present and the hardware should be in good condition.
6. Remove anything that does not belong in the path of the Swing door. There should be no bulletin boards, literature racks, merchandise displays, or other attractions in the door area that would interfere with use of the door or invite people to stop or stand in the door area.
7. Ensure the Header Cover and all other hardware is properly secured.
8. Check for damaged or missing weather stripping.
9. If Equipped: Test Emergency Break Out. In Break Out mode, the door must not activate. Call your supplier for details.
10. Have the Low Energy automatic door system inspected at least annually by an AAADM certified inspector.

SAFETY

INFORMATION

Low Energy Swinging Doors

These minimum safety checks, in addition to those in the Owner's Manual, should be made each day and after any loss of electrical power.

1. Activate this door. Door should open at a slow, smooth pace (4 or more seconds) and stop without impact.
2. Door must remain fully open for a minimum of 5 seconds before beginning to close
3. Door should close at a slow, smooth pace (4 or more seconds) and stop without impact.
4. Inspect the floor area. It should be clean with no loose parts that might cause user to trip or fall. Keep traffic path clear.
5. Inspect door's overall condition. The appropriate signage should be present and the hardware should be

AAADM

American Association of Automatic Door Manufacturers

at least annually.

DONOT USE DOOR if it fails any of these safety checks or if it malfunctions in any way. Call a qualified automatic door service company to have door repaired or

PLACE COMPLETED ANNUAL COMPLIANCE INSPECTION LABEL HERE



Always follow the safety sensor devise manufacturer's detailed installation, commissioning, and testing instructions.

Section 14.0 - Additional Information

Floor Space Requirements for Wheelchair Maneuvering

- The owner may request the activation device location; however, the press switch must be in view of the door and not directly in the door or frame. Please refer to ANSI 117.1 Safety Code for further guidelines on switch requirements.
- Activation switches shall be at a minimum height of 34" and maximum height of 48" from finished floors.
- Individuals who use a wheelchair need a minimum of 48" clearance to the door swing for doors in series.

External and Internal

Factors Door Condition

- Door must move easily open and close (latch) without excessive force; weather stripping and threshold must not interfere with door movement.

Reveal

- For out swing (Push) doors, the reveal must be within the range of 0" to 14". For in swing (Pull) doors, 0" to 4" for special reveals is allowed - for all others, consult factory.

Wind

- When installing on a door in a strong wind condition area, special adjustments should be made to the arm and doorstop position. To increase the tension spring, consult factory.

Power/Control Wires

- Check that the electrical feed, all conduits, and electrical junction boxes (for push plates or other activation devices, if require) are correctly located in accordance with final approved shop drawings and within the guidelines of the enforced local electrical codes.

Electronic equipment reception interference

The equipment complies with the European EMC directive (U.S. market FCC Part 15) provided installed according to installation and service manual.

The equipment may generate and use radio frequency energy and if not installed and used properly, it may cause interference with radio, television reception, or other radio frequency type systems.

If other equipment does not fully comply with immunity requirements, interference may occur. However, there is no guarantee that interference will not occur in a particular installation. If this equipment does cause interference to radio or television reception, which can be determined by turning the equipment off and on, the user is encouraged to try to correct the interference by one or more of the following measures:

- ◆ Re-orient the receiving antenna
- ◆ Relocate the receiver with respect to the equipment
- ◆ Move the receiver away from the equipment
- ◆ Plug the receiver into a different outlet so that equipment and receiver are on different branch circuits
- ◆ Check that the protective earth (PE) is connected
- ◆ If necessary, the user should consult the dealer or an experienced electronic technician for additional suggestions.

Micom Americas products are equipped with electronics and may also be equipped with batteries containing material which are hazardous to the environment. Remove this material from the operator before it is scrapped and make sure that it is disposed of properly as was done with the packaging.

This manual contains the necessary details and interactions for the installation, maintenance, and service of the swing door operator.

Section 15.0 - Preload Spring Tension

Always place the 2 Allen screws at the back of the gear box so the open front faces you.

Step 1: Start by letting the spring unload itself

Step 2: Loosen mechanical stop on the spindle and side away from gearbox.

Step 5: Set the mechanical stop just above this screw at 9 o'clock and let rest against it

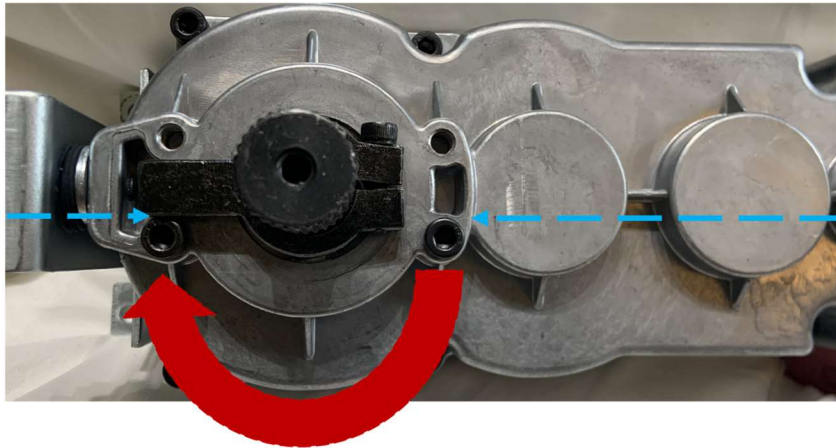

Step 3: Remove mechanical stop from spindle and reset just above this screw at 3 o'clock position

Step 4: Turn clockwise for this application (RHR or Left Hand Push) about 180°

This amount of rotation provides a pre-load for about 11-15 lbf of force on a 36" door when opened manually.

You can add more rotation if needed to close in a windy or high stack pressure application

****You can also decrease rotation for interior application or easier to open manual door****

Do this in small increments of 30° at a time to achieve a higher/lower pre-load to close the door.

In example above: relocate un-sprung mechanical stop at 2 o'clock, 1 o'clock, or 12 o'clock for more manual closing force

For less force and easier to open manually start at 4 o'clock/30° less

Generally acceptable range is 150° to 270°

Section 16.0 - Drop Spindle Instructions

Determine how much you need to drop the spindle to securely attach the operator to the wall and door frame and ensure the operator arm clears the door jambs while in operation.

Step 1: Remove the motor/gearbox from the aluminum header following instructions in Section 5.5.

Step 2: Remove the 1/4" x 20 screw/bolt and large washer attached to the spindle at the top of the gearbox.

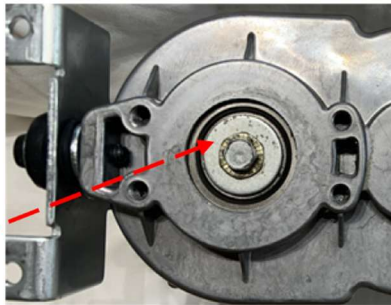

Step 3: Loosen the mechanical stop and slide it away, be careful and let the spindle unwind itself from the gearbox.

Step 4: Tap the spindle at the top and slide it down to desired length.

Step 5: Select a 1/4" x 20 threaded bolt to achieve the desired amount of drop you need, see below guide.



Drop Spindle Guide

To get the amount of drop needed subtract 1/2" from the bolt length. Example: 2.75" bolt = 2.25" drop etc.

**You can drop the spindle up to a maximum of 2.75".
You must keep a minimum of 1" of the spindle shaft in the gearbox.**

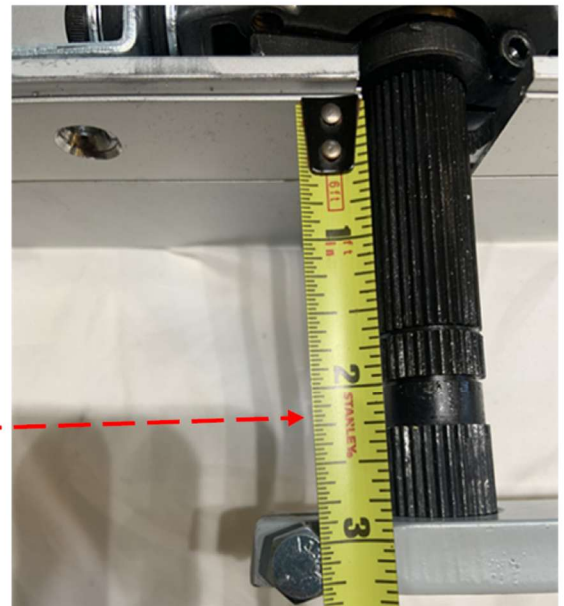

Step 6: Reattach the bolt and washer to the spindle at the top of the gearbox making sure you use a small amount of blue Loctite. No spacers are needed.

Step 7: Closely follow the Preload Spring Tension instructions in Section 15.0, making sure you achieve the amount of desired opening and closing forces while complying with ANSI A156.19.

** Each installer should carry a selection of 1/4 x 20 standard threaded bolts **
** 1.0", 1.25", 1.5", 1.75", 2.0", 2.25", 2.5", 2.75" and 3.0" lengths **

Section 17.0 - Miscellaneous/Future Use

Section 18.0 - Warranty Policy

Automatic Door Operators SW-800 and SW-800C shipped after April 1, 2021 carry a 3-year warranty from date of shipment or official installation date, whichever is greatest, proven by a copy of a Micom Dealer work order indicating the installation date.

Accessories such as sensors, push plates, hardware, etc., are covered under the applicable manufacturer's warranty in effect at time of purchase.

Standard and Custom finish warranties are covered under the applicable manufacturer's warranty in effect at time of purchase. For specific finish warranties, contact customer service. Finishes include, but are not limited to, anodized, powder coating, wet paint, and all cladded materials.

All other products not mentioned above are covered under a standard 1-year warranty, unless expressed in writing.

All goods sold are warranted to be free from defects in material and workmanship - the foregoing comprises seller's sole and entire warranty. All other warranties, written or verbal, expressed or implied, and including, but not limited to, warranties of merchantability or fitness for intended purpose are expressly excluded.

Seller's sole obligation under these warranties, during the period after date of manufacture as listed above, shall be to issue credit, repair, or replace any items or part thereof which is proved to be other than as warranted. Seller shall have the sole right to determine whether such parts shall be repaired or replaced or whether credit shall be issued. No allowance shall be made for any labor charges for replacement of parts, adjustments or repairs, or any other work. In no event shall seller be liable for collateral, liquidated or consequential damages.

If goods are claimed to be other than as warranted, seller, upon notice promptly given, will either examine the goods at their site or issue shipping instructions for return to seller (transportation costs prepaid by buyer). These warranties shall not extend to any goods or parts thereof which have been subjected to misuse or neglect, damage by accident, rendered defective by reason of improper installation or by the performance of repairs, modifications or attachment to other products outside of seller's plant.

Because Micom has no control over conditions under which its products are used, Micom specifically does not warrant the adequacy or sufficiency of any device or recommendations given to buyer. Nor does Micom warrant that every Micom product complies with every code, standard or regulation in every community except as specifically stated in a published Micom technical documentation or in writing by an officer of the company. Nor is Micom bound by the terms of buyer's agreements with other parties.

For projects located outside the United States or Canada, the limited warranty period for all products is 1 year from the date of manufacture.

Micom Americas regional businesses located outside the United States or Canada may offer different warranty periods. "United States or Canada" is defined as the several states of the United States, the District of Columbia, the commonwealths, territories and possessions of the United States, and all of the Canadian provinces and territories.

BACK COVER